



**Eurotec Finishing Systems Limited**

Unit 4 Lockflight Buildings, Wheatlea Industrial Estate,  
Wigan WN3 6XR

Phone: 01942 829 111 Fax: 01942 820 491

<http://www.eurotecfinishing.com> e-mail : [enquiries@eurotecfinishing.com](mailto:enquiries@eurotecfinishing.com)

**SYSTEM CONTROL UNIT  
SCU 300**

*INSTRUCTION MANUAL*

<b>DOCUMENT:</b>	<b>System Control Unit - <i>Manual</i></b>
<b>DATE ISSUED:</b>	<b>13 September, 1999</b>
<b>ISSUE NUMBER:</b>	<b>1</b>

## **CAUTION**

This equipment can be dangerous unless it is used in accordance with the rules laid down in this manual.

Read this manual completely before installing and operating the equipment.

Ensure all safety instructions and procedures are correctly followed and that all operators are fully trained.

**IMPORTANT:** *All other manuals relevant to components and equipment of the installation must be followed.*

## ***CONTENTS***

- 1. Title**
- 2. Caution**
- 3. Contents**
- 4. Declaration of Conformity**
- 5. System Control Unit**
- 6. Specification, SCU-300**
  - *Weights and Dimensions*
  - *Electrical Data, Electrical Controls*
  - *Pneumatic Data, Pneumatic Controls*
- 7. SCU-300 General Assembly Drawing**
- 8. Front Panel Symbols Explanation**
- 9. Rear Panel Symbols Explanation**
- 10. Parts List**
- 11. Schematic Diagrams**
  - *SCU-300 Pneumatic Diagram*
  - *SCU-300 Wiring Diagram*

## EC Declaration Of Conformity

We, Eurotec Finishing Systems Limited declare that the following product,

**Description:** System Control Unit  
**Model:** SCU-300

**Use:** Electrostatic Powder Coating System Control Unit

was manufactured by ourselves and conforms with the following standard (s) and /  
or other normative document (s):

EC Machinery Directive 89/392/EEC  
EC Low Voltage Directive 73/23/EEC  
EC Directive of Electromagnetic Compatibility 89/336/EEC  
Electrostatic Painting and Finishing Equipment Using Flammable

Materials

EN50 050:1986 and EN50 053:Part 2:1989

Signed on behalf of Eurotec Finishing Systems Ltd. by



Mr. D.H. Campbell  
Technical Director

**Eurotec Finishing Systems Limited**  
Unit 4 Lockflight Buildings, Wheatlea Industrial Estate, Wigan, WN3 6XR  
Tel: 01942 829111 Fax: 01942 820491  
V.A.T. Reg. No. 535 0123 87  
Company No. 3008563 Registered In England

## **SCU-300 SYSTEM CONTROL UNIT**

### **GENERAL DESCRIPTION**

#### **Part No. 2021002**

The System Control Unit (SCU) provides the master control functions for the powder application equipment of an automatic powder coating system.

It provides for switched distribution of mains air and electrical supplies for up to nine gun control units. A connector on the rear panel enables the electrical supply to the gun control units to be triggered externally e.g. by photo-detectors across a spray booth to detect the presence or absence of product. Spray guns may therefore be switched on and off together from an external source.

It provides for independently switched mains electrical outputs for running or triggering two gun manipulators/robots e.g. Reciprocators or Swingers.

Three regulated air supplies are available via pressure regulators and gauges on the front panel. Two of these have regulation to a max. of 2 bar (30 psi) and would normally be used to supply the fluidising air on fluid beds. The third is regulated to a max. of 4 bar (60 psi) and could be used for any ancillary pneumatic equipment e.g. pneumatic vibratory sieves, powder transfer pumps etc.

The incoming air supply is switched through a high capacity solenoid valve operated by a switch on the front panel.

The incoming electrical supply is switched through a power failure release switch on the front panel, which enables safe interlocking with other parts of a system e.g. extraction systems, conveyors etc. The main switch must be reset manually if the emergency stop is operated.

An emergency stop button is provided on the front panel with a facility via a rear panel connector to connect external emergency stop stations. The main switch must be reset manually if the emergency stop is operated.

The main switch and emergency stop button control all spray gun and gun mover functions of the System Control Module and therefore controls all automatic equipment connected to it, with the exception of the non-switched mains output supply.

An additional non-switched supply outlet is available for connecting auxiliary equipment which is not required to be switched off by the system control emergency stop facility e.g. control units for manual guns etc.

## SPECIFICATION

### Weights & Dimensions

<b>Nett Weight:-</b>	15 kg.
<b>Nett Dimensions:-</b>	360 x 360 x 118 mm.
<b>Packed Weight:-</b>	15.8 kg.
<b>Packed Dimensions:-</b>	510 x 400 x 160 mm.
<b>Total Packed Volume:-</b>	0.0326 cubic metre.

### Electrical Data

<b>Input Voltage:-</b>	100-130/200-260 Volts, 50/60 Hz, Single Phase.
<b>Input Current:-</b>	Max. 16 amps.
<b>Output Current:-</b>	Switched mains output to gun control modules, <i>6 amps Max</i> 2 independently switched mains outputs to gun manipulators, <i>6 amps Max</i> . Non switched supply to auxilary equipment, <i>10 amps Max</i> .
<b>Remote and Trigger Outputs:-</b>	24 Volts a.c. to remote emergency stop stations. 24 Volts a.c. to remote trigger/sensor contacts.

### Electrical Controls

<b>Mains Isolator - Front Panel</b>	Rotary 2 position solenoid latching (0V release type) Off/On (The emergency stop button illuminates when switch is On), Controls mains supply to the SCU with the exception of the supply to the non-switched mains electrical output.
<b>Mains Output Switch - Front Panel</b>	Rotary 2 position Off/On. Controls the mains electrical supply to the Gun Control Units. This switch is interlocked with the mains air switch. <b>NOTE:-</b> The mains air must be switched on in order to obtain mains electrical output to the Gun Control Units.
<b>Mains Air Switch - Front Panel</b>	Rotary 2 position Off/On. Controls the incoming mains air supply.
<b>Emergency Stop Button - Front Panel</b>	Switches off all electrical and pneumatic functions, with the exception of the non-switched mains output.
<b>Manipulator Switch No. 1. - Front Panel</b>	Rotary 2 position Off/On. Controls the mains electrical supply/trigger to a gun manipulator.
<b>Manipulator Switch No. 2. - Front Panel</b>	Rotary 2 position Off/On. Controls the mains electrical supply/trigger to a second gun manipulator.
<b>Mains Voltage Selector Switch - Rear Panel</b>	Slide 2 position - 100-130/200-260 volts.

## **Circuit Protection**

### **- Rear Panel**

#### *Miniature circuit breakers:-*

Mains input	16A
Mains transformer primary	0.6A at 115V 0.3A at 230V
Mains transformer secondary	2A at 24V
Mains output, GCU	6A
Mains output, gun robots	6A each

### **Non-Switched Mains Output Connector - Rear Panel**

Non-switched mains output via connector to IP65.

### **Switched Mains Output Connector - Rear Panel**

Switched Mains output to via connector to IP65. (Powers gun control units etc.(Voltage as input)).

### **Manipulator 1 & 2 Output Connectors - Rear Panel**

2 individual connectors to IP65. (Mains output voltage as input).

### **Remote and Trigger Output Connector - Rear Panel**

Via connector to IP65. (For connection to remote emergency stop stations or remote trigger/sensor contacts.

### **Pneumatic Data**

#### **Input air pressure**

7.0 bar (100 p.s.i.) Max.

#### **Input air conditioning**

Oil free to 0.1 p.p.m. and dry to 1.3 g/cubic Nm.

#### **Air consumption (Typical)**

10.0 cubic m/h. (6.0 c.f.m.) per gun.

10.0 cubic m/h. (6.0 c.f.m.) per fluidised bed.

#### **Input Connection - Rear Panel**

1.0" ID hose tail on a swivel elbow.

### **Pneumatic Controls**

#### **Incoming solenoid valve**

Normally closed, opens on operation of mains air switch. Controls all regulated and non-regulated outputs.

#### **Pressure regulators and gauges**

These control the air supply pressure to the following outputs:-

- 1) *Fluidised Bed No. 1:-* Controls the fluidisation level of a fluidised bed.
- 2) *Fluidised Bed No. 2:-* Controls the fluidisation level of a second fluidised bed.
- 3) *Regulated Supply No. 3:-* Controls air pressure to auxiliary equipment e.g. vibratory sieves or powder transfer units.

#### **Pneumatic Outputs - Rear Panel**

*9 non-regulated outputs (numbered 1-9):-*

8mm push-in fittings to supply gun control units. Unused outputs may be fitted with blanking plugs.

*1 regulated output (labeled AUX):-*

8mm push-in fitting to supply auxiliary equipment such as vibratory sieves or powder transfer units.

*2 regulated outputs (labeled):-*

8mm push-in fittings to supply fluidising air to fluid beds.

# System Control Unit SCU-300 General Assembly

Part No. 2021002

Illustration 6000071

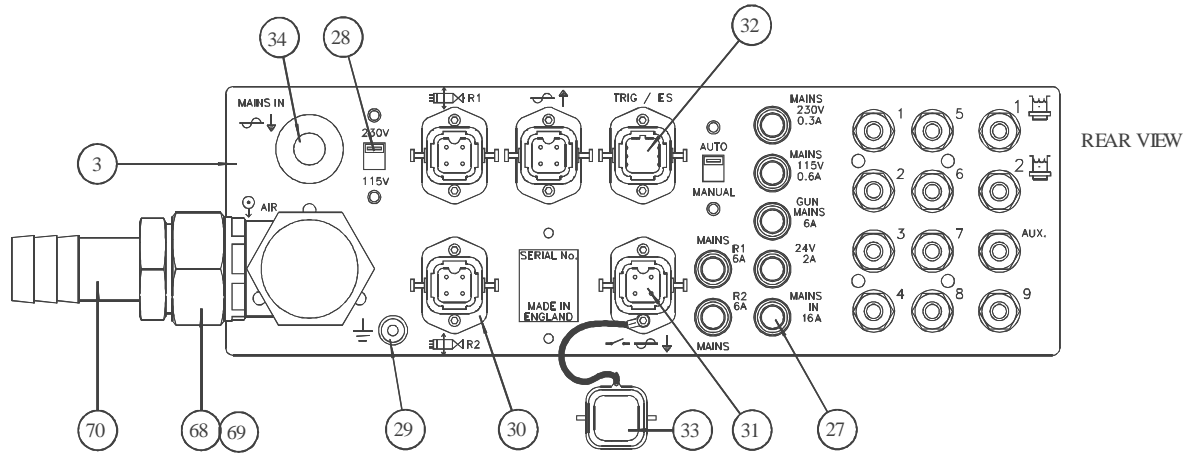
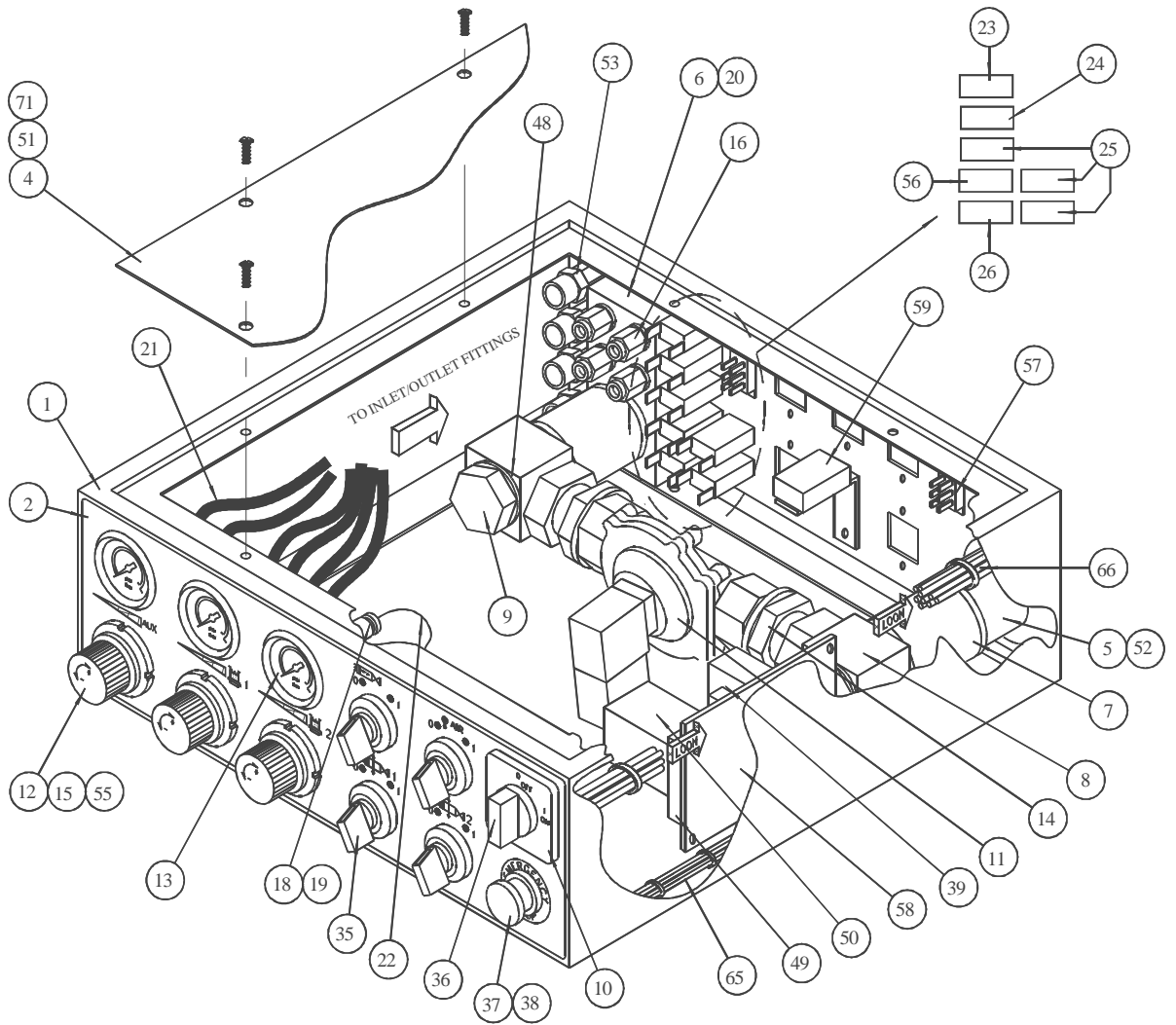



# System Control Unit SCU-300

## Front Panel Symbols Eplanation

Illustration 6000069

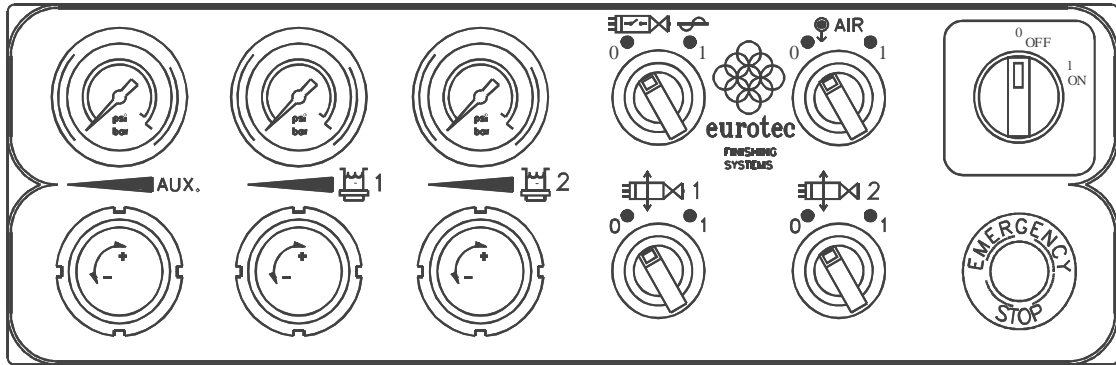

**AUX.**                    A SWITCHED REGULATED AUXILLIARY AIR SUPPLY



A SWITCHED REGULATED AIR OUTPUT TYPICALLY FOR FLUID BED PLENUM CONNEC



A SWITCHED REGULATED AIR OUTPUT TYPICALLY FOR FLUID BED PLENUM CONNEC



ON/OFF POWER SUPPLY TO GUN CONTROL UNITS

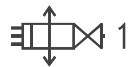

ON/OFF TRIGGERING SUPPLY FOR GUN MANIPULATORS

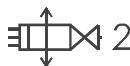

ON/OFF TRIGGERING SUPPLY FOR GUN MANIPULATORS











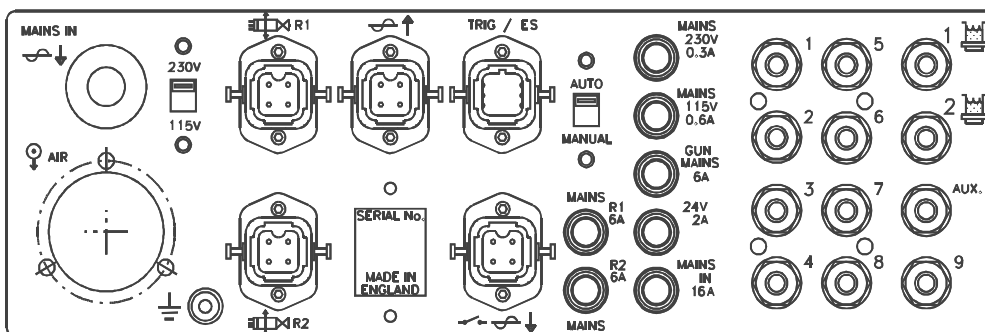





ON/OFF INCOMING AIR SUPPLY

# System Control Unit SCU-300

## Rear Panel Symbols Eplanation

Illustration 6000070



- 
MAINS SUPPLY IN
- 
MAIN AIRLINE SUPPLY IN
- 
MAINS VOLTAGE SELECTOR
- 
GUN MANIPULATOR TRIGGER SUPPLY No.1
- 
MAINS SUPPLY OUT
- 
REMOTE TRIGGER EMERGENCY STOP
- 
EARTH POST CONNECTION
- 
GUN MANIPULATOR TRIGGER SUPPLY NO.2
- 
SWITCHED MAINS SUPPLY OUT
- 
FLUID BED NO.1 REGULATED PLENUM AIR SUPPLY
- 
UNREGULATED AIR SUPPLY OUTLETS FOR CONNECTION TO GUN CONTROL
- 
REGULATED AND SWITCHED AUXILLIARY AIR SUPPLY OUTLET
- 
RESETABLE CIRCUIT BREAKER FUNCTION AND RATING

**SCU-300 General Assembly**  
**PARTS LIST**



<b>Item</b>	<b>Part No.</b>	<b>Description</b>	<b>Qty</b>
1	2012010	System control box	1
2	2021011	Front overlay	1
3	2021012	Rear overlay	1
4	2020027	Cover, detail	2
5	2001015	Air inlet fitting	1
6	2001018	Manifold, distribution system	1
7	2001020	Banjo spacer, 1"-3/4" BSP	2
8	2001021	Banjo body, 3/4"-1" BSP	2
9	2001022	Banjo bolt, 3/4" BSP	2
10	2001016	Nutplate, main isolator	1
11	9000100	Valve, solenoid 2-2, 1" BSP, 24V a.c.	1
12	9000112	Pressure regulator, 4 bar	3
13	2020023	0-4 pressure guage	3
14	2001031	Connector, swivel, male/female 1" BSP	2
15	9000097	Elbow, 1/4" BSPMT-8mm OD tube PI	6
16	9000030	Straight, 1/4" BSPMT-8mm OD tube PI	12
17	9000192	Straight, 1/4" BSPMP-5/16" OD tube CF	4
18	9000052	Straight, 1/8 BSPFP-4mm OD tube PI	3
19	9000071	O-ring 009	3
20	9000102	Blank, 3/8" BSPMT, hex, skt	2
21	9000171	Tubing, 8mm OD x 5.5mm ID, PU, black	2m
22	9000203	Tubing, 4mm OD x 2.5mm ID, PU, black	2m
23	9000015	Circuit breaker, 0.3A, thermal sub-min	1
24	9000016	Circuit breaker, 0.6A, thermal sub-min	1
25	9000018	Circuit breaker, 6A, thermal sub-min	3
26	9001294	Circuit breaker, 16A, thermal sub-min	1
27	9000019	Boot, circuit breaker cover	7
28	9000020	Switch, voltage selector, 2 position	1
29	9000021	Terminal, earth post	1
30	9000120	Connector, base panel mount	5
31	9000012	Connector socket insert, 3 pin + E	4
32	9000342	Connector socket insert, 6 pin low volt	1
33	9000014	Connector, protective cover	5
34	9000194	Gland, cable, M20, nylon	1
35	9000156	Switch, rotary, 1 pole, C/O	4
36	9000154	Switch, no volt release, 24V coil	1

Continued:-

Item	Part No.	Description	Qty
37	9000155	Switch, push button, red, 1 pole C/O	1
38	9000202	Bulb, 28V, SX6S	1
39	2001010	Transformer, mains, 24V, 15A	1
40	9000500	Screw, M3x10, skt, cap, black	14
41	9000551	Screw, M4x8, skt, btn, black	12
42	9000561	Screw, M4x35, skt, csnk, black	2
43	9000556	Screw, M4x16, pos, cnsk, s.stl	4
44	9000800	Nut, M3, nyloc	4
45	9000801	Nut, M4, nyloc	4
46	9000600	Screw, M5x6, skt, cnsk, black	16
47	9000650	Screw, M6x12, skt, btn, black	2
48	2001033	Washer, sealine, 3/4" BSP, bonded	2
49	9000197	Relay base, 8 pin	1
50	9000152	Relay, 2 pole, 24V a.c, 8 pin	1
51	9000205	Label, warning, disconnect from mains	1
52	9000327	1" seal	6
53	9000009	Straight, 1/4" BSPFP-8mm OD tube PI	4
54	5000040	Disc, porous plastic, 8mm x 4.75mm thk	3
55	9000062	Elbow, 1/8" BSPMT-4mm OD tube PI	3
56	9000017	Circuit breaker, 2A, thermal sub min	1
57	9001202	Switch, slide, 2 position	1
58	2010015	Mains TX mount plate	1
59	9000204	Terminal block, 3 way, shrouded	1
60	9000451	Cable, 3 core, 1.5mm S.Q, black	5m
61	9000193	Blank, 8mm OD, brass CF	1
62	9000008	Cable tie base, self adhesive	3
63	9000344	Cable tie, large	2
64	9000842	Washer, 1/8" BSP, nylon, sealing	4
65	2021007	Low volt loom assembly	1
66	2021006	Mains loom assembly	1
67	9001492	Cover, terminals (transformer)	1
68	9001438	1" adapter	1
69	9001439	1" swivel elbow	1
70	9001440	Hose tail, 1" ID-1" BSPMP	1
71	9001496	Label, caution set voltage selector	1

# System Control Unit SCU-300 Pneumatic Diagram

Illustration 6000075

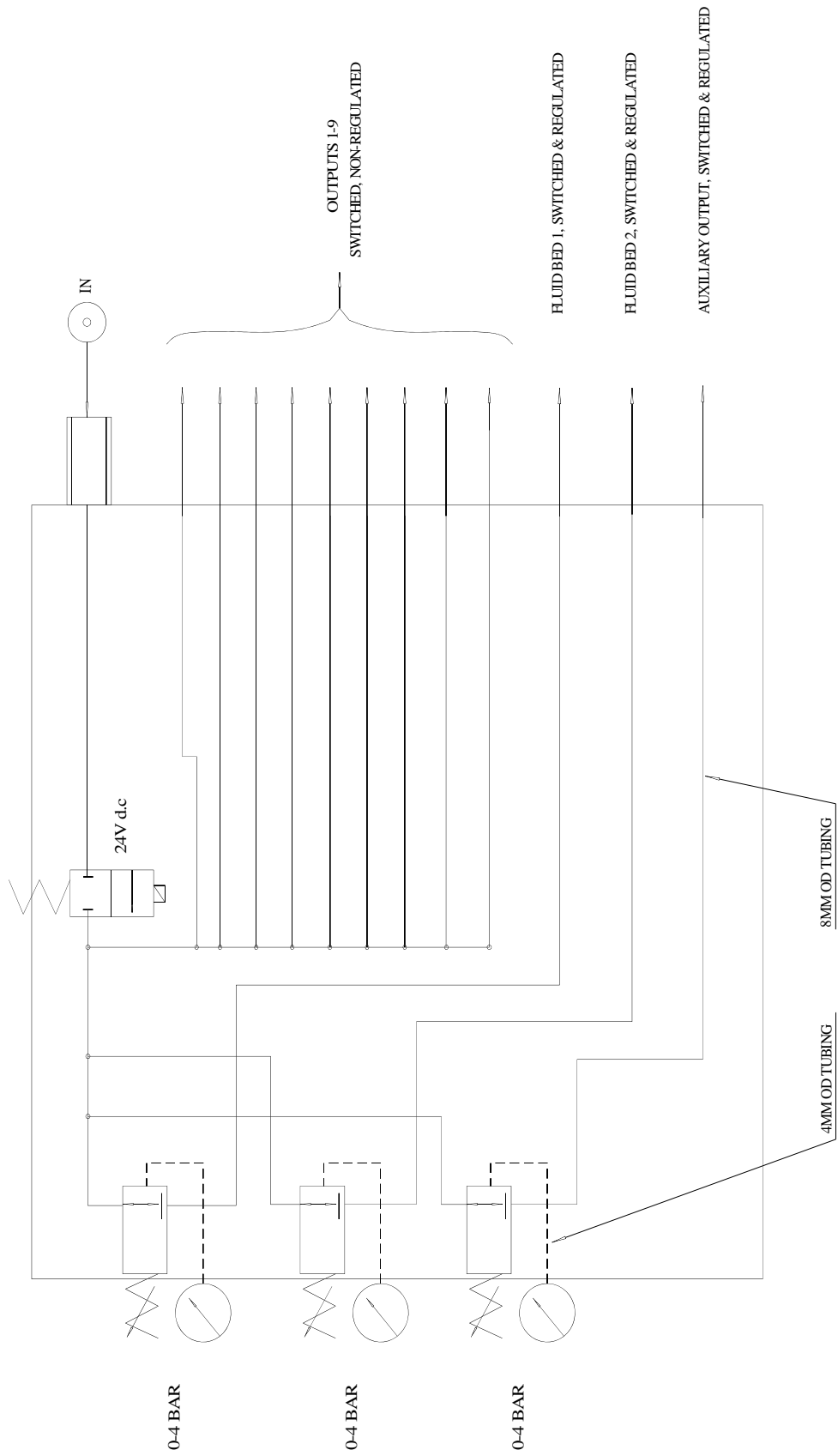

# System Control Unit SCU-300 Wiring Diagram Illustration 6000072

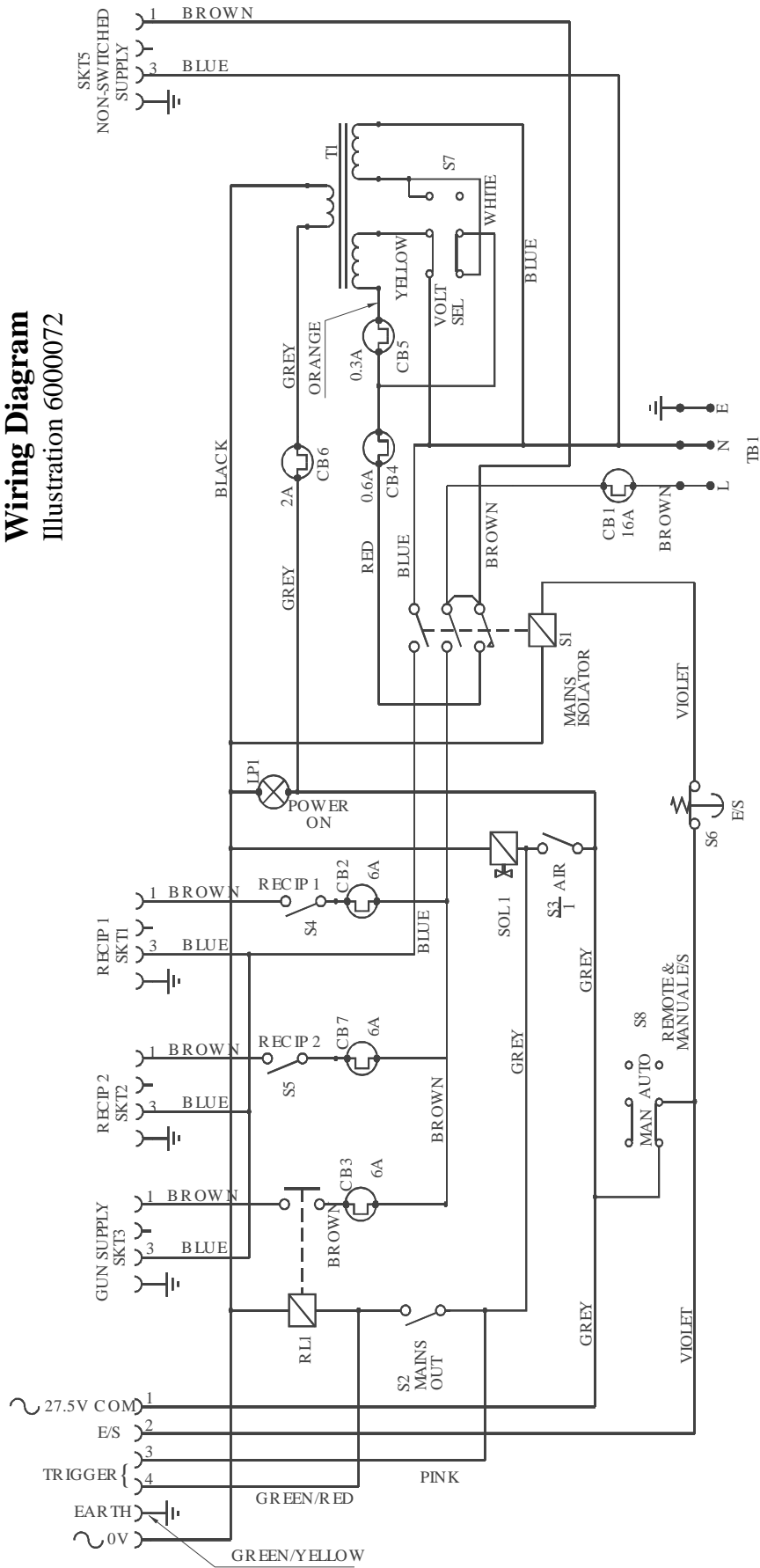

***NOTES:***

